

**CSAG SERIES PMS
ELEVATOR TRACTION MACHINE**

Assembly and Service Instruction Book

S14.01



Contents Index

1. General-usage to intended purpose

- 1.1 Safety declaration
- 1.2 Checking before usage
- 1.3 Operating conditions
- 1.4 Installation
- 1.5 Type code
- 1.6 Nameplate
- 1.7 Product description
- 1.8 Usage regulation
- 1.9 Transport and storage

2. Electrical connection

- 2.1 General
- 2.2 Motor connection
- 2.3 Thermal resistance
- 2.4 Brake and switch
 - 2.4.1 Brake
 - 2.4.2 Microswitch
- 2.5 Encoder connection
 - 2.5.1 Pulse encoder
 - 2.5.2 Sin/cos encoder
 - 2.5.3 Endat encoder
- 2.6 Earthing

3. Operation and maintenance

- 3.1 General
- 3.2 Maintenance intervals
- 3.3 Maintenance regulation
- 3.4 Lubricating instructions
- 3.5 Brake operation device
- 3.6 Sheave replace
- 3.7 Trouble shooting

4. Brake system

- 4.1 General
- 4.2 Brake system declaration
- 4.3 Micro-switch adjustment
- 4.4 Start-up
- 4.5 Brake system adjustment
- 4.6 Trouble shooting

1. General-usage to intended purpose

5. Synchronization with inverter

- 5.1 General
- 5.2 Checking before usage
- 5.3 Motor parameter setting
- 5.4 Inverter self-learning condition and method
- 5.5 Connexion to the most common Inverter Models

Annex I: Encoder installation

- I.1.- General
- I.2.- Installation regulation
- I.3.- Installation

Annex II: Technical data

Thank you for purchasing our CSAG series PM elevator traction machine. In order to enable users to make clear about our product's function, characteristics, etc and ensure users' safety, please read this operation and service manual carefully. When any problem beyond this manual is found during installation and or use, please contact local sales agency or our technicians at the engineering department. They will be delighted in servicing you.

1.1 Safety declaration

Only qualified technicians are allowed to perform any planning, installation or maintenance work to CSAG series gearless PMS elevator traction machines. They must be trained and familiar with the installation, assembly, connexion and operation of the product. Sufficient knowledge in lift construction is essential. The connexion of the product is prohibited until the requirements of the directive are satisfied by or upon integration of the motor into the final product.

The regulations concerning operation, maintenance and inspection in accordance with the applicable safety regulations in lift construction such as GB 7588-2003 "Safety rules for the construction and installation of electric lifts" (equal to EN81-1:1998) / GBT 21739-2008 "Rules for the construction and installation of home lifts" and other relevant regulations shall be strictly observed.

The operator is responsible for the proper installation of the gearless PMS elevator traction machine with regard to safety requirements as well as for its inspection and maintenance as specified in the applicable regulations. No liability can be assumed for any damage caused by improper handling or any other acts, which are not in conformity with these operating instructions and thus deter from the qualities of the product.

In this manual, the following pictographs are used to mark warnings and important notes. These pictographs must be observed and instructions carefully followed.



Mean that death or serious injury to persons or serious damage to property will occur unless the appropriate precautions are taken.



may

Mean that death or serious injury to persons or serious damage to property may occur unless the appropriate precautions are taken.



Mean that injuries to persons or damage to property may occur unless the appropriate precautions are taken.

The operator must observe and follow the safety points in this manual strictly.

1.2 Checking before usage

Before you start using the machine, you should check the following points earnestly:

- a. Check up whether the packages is integrity or not before opening it, and make sure there is no injured or affected with damp;

- b. Check up whether the machine documents and other related accessories is well found or not;
- c. Check up the nameplate data seriously, and make sure that this type of machine is according with the installation specifications;
- d. Check up whether the traction machine structure is integrated or not, whether the bolt fix tight or not, and whether the brake system is working agile or not;
- e. Measure the insulation resistances of the PMS motor windings and brake windings. If the insulation resistances dropped below 3 MΩ the winding needs to be dried (insulation meter voltage: 500V DC);
- f. Check up whether the brake system work effective and brake manual handle device work agile and effective or not.

1.3 Operating conditions

C- ACT Series Gearless PMS elevator traction machines must be ensured on following ambient conditions:

- a. Altitude: Max. 1000 m (If the altitude bigger than 1000m, please contact our technical department);
- b. Ambient temperature: 5~40 °C;
- c. Max. Relatively humidity: 90% at 25 °C (no moisture condensation);
- d. Atmosphere air around the machine without causticity, combustible gases or pungent gases;
- e. No lubricant and sundries on rope surface;
- f. Car weight, counterweight and wrapping angle should be accordance with the relative regulations.

1.4 Installation

Check the permissible base frame or foundation loads by calculation before installing the lift machine.

Place the machine on a plane surface with a permissible deviation from planeness not exceeding 0.1 mm.

Danger

Fasten the machine on the frame with four bolts of strength class 8.8.

Warning

Traction machines are generally provided with rope slip-off guards. After putting the ropes in place, adjust them so that the distance between the rope and the rope slip-off guard does not exceed 1.5 mm.

Install the machine only in an enclosed machine room and take care to observe the relevant safety precautions.

Traction machines are designed with degree of protection IP 41. Make sure that the cable entries to the terminal boxes are sealed properly when making the electrical installation.

The revolving parts must be defend according to GB 7588-2003 "Safety rules for the construction and installation of electric lifts".

1.5 Type code

CSAG - X. XXXX. XXX

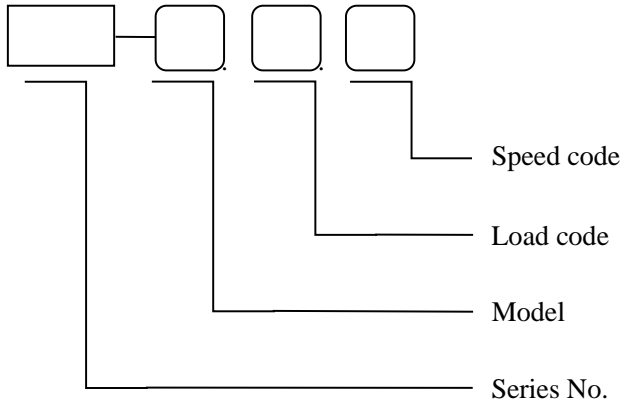

For example: CSAG-L.1000.100 Type means this machine is CSAG-L gearless PMS elevator traction machine, rated load is 1000kg, and rated speed is 1.0m/s.

Customer can choose our gearless PMS elevator traction machine by rated load, rated speed and series code (you can also see our gearless PMS elevator traction machine catalog for details).

1.6 Nameplate



The nameplate will be riveted on the machine body, it includes some necessary parameters in setting frequency inverter.

Please refer to the given parameters in order to set the frequency inverter to work properly.

1.7 Product description

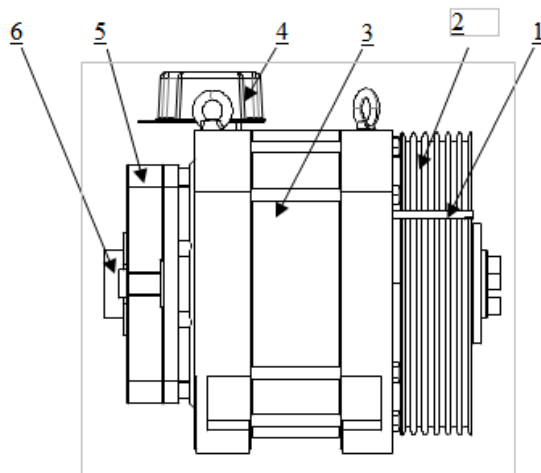

1.7.1 CSAG-L (630-1000kg , Sheave diameter : D400mm)

- 1、Ward off rope device 2、Sheave 3、PMS motor 4、Connection box 5、Brake system 6、Encoder

1.7.2 CSAG-K (630-1000kg, Sheave diameter : D320mm)

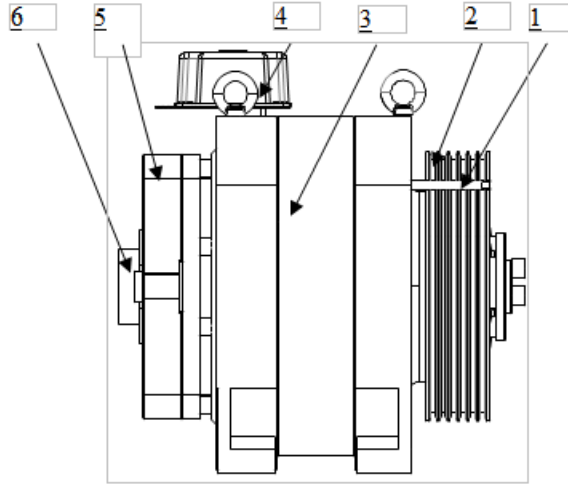

- 1、Ward off rope device 2、Sheave 3、PMS motor 4、Connection box 5、Brake system 6、Encoder

1.7.3 CSAG-N (450kg-1000kg, Sheave diameter : D320mm)

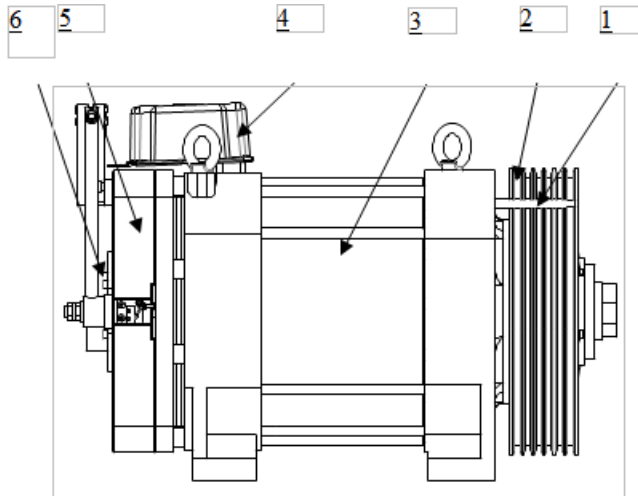

- 1、Ward off rope device 2、Sheave 3、PMS motor 4、Connection box 5、Brake system 6、Encoder

1.7.4 CSAG-M (320kg-450kg, Sheave diameter : D210mm)

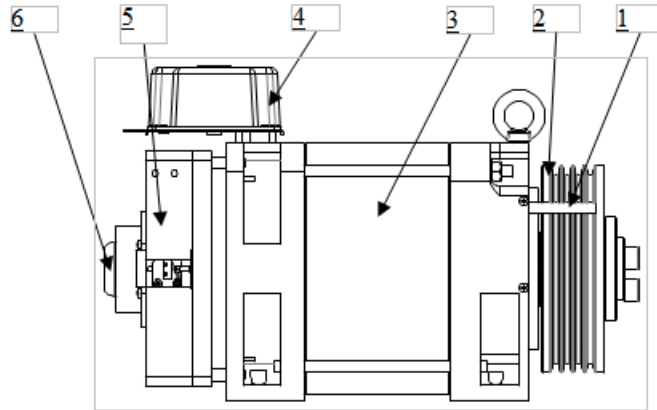

- 1、 Ward off rope device 2、 Sheave 3、 PMS motor 4、 Connection box 5、 Brake system 6、 Encoder

1.8 Usage regulation

Warning

The Gearless PMS elevator traction machines are not designed for direct connection to the three-phase system but are to be operated via an electronic frequency inverter. Direct connection to the system may destroy the motor.

Due to use high-frequency inverter the surface of machine may induce some Faraday current during operation of synchronous motors. So the Earthing should be connect at terminal connection box.

High voltages may occur at the terminal connections during the operation of synchronous motor, so the installation or maintenance work is forbidden when the power is not take off.

Check the proper functioning of the motor and the brake after installing the machine.

Caution

High surface temperature may occur on the external parts of the machine. Therefore, no temperature-sensitive parts may contact these parts or be attached to them. Protection against accidental contact should be provided, if required.

1.9 Transport and storage

The PMS elevator traction machines leave factory in a faultless condition after being carefully tested. Make a visual check for any external damage immediately upon their arrival on site. If any damage incurred during transit is found, make a notice of claim in the presence of the forwarder. If necessary, do not put these machines into operation.

The eyebolts are designed for the specified machine weight, i.e. it is not permitted to suspend additional loads. And the machine must be suspend in a right method (see following picture for detail).

Store the machine only in closed, dry, dust-free, well ventilated and vibration-free rooms.

After prolonged storage (>6 months), rotate the motor in both directions at a low speed (about 20rpm) to allow the grease to distribute evenly in the bearings.

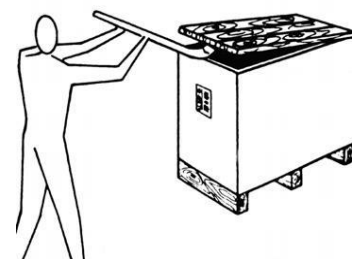
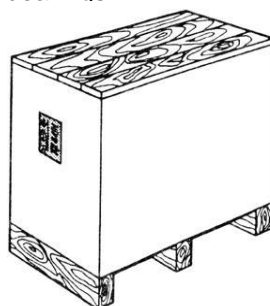

MAX 30 cm

2. Electrical connection

2.1 General



The electrical connection of the motor should be done by qualified electric technicians. There must be no foreign bodies, dirt or moisture in the terminal box. In order to keep the connection safe, please pass the cable through the hole with the water joint into the

connection box. Do not forget to settle the “connection box cover” after connecting the cables, to avoid an electric shock.

2.2 Motor connection



Direct connection to 380V three-phase power is forbidden, it may destroy the motor and invalidate guarantee.

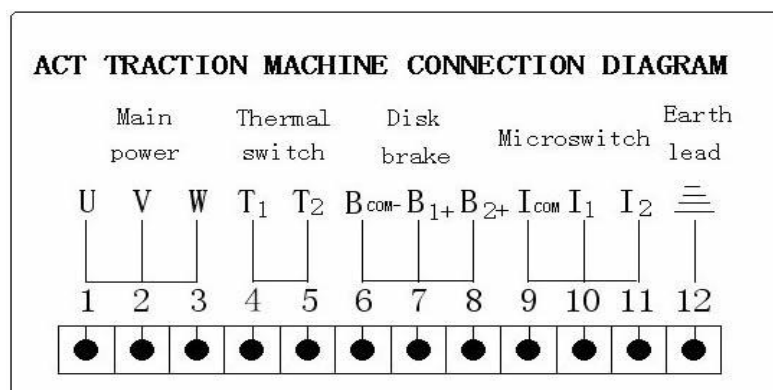

Always connect the frequency inverter output and earthing terminal to motor terminal as shown in the picture. The connection cable diameter is decided accordingly to the motor rated current (can refer to frequency inverter instruction manual).

Check the short-circuiting between windings and ground after connection.

2.3 Thermal resistance

In order to control any increase of the motor temperature and avoid motor damage due to high temperature, every CSAG series gearless PMS elevator traction machine install a thermal protection resistance, customer can connect the “R1, R2” terminal to their control system. The following table is the specification of the PTC thermal resistance used by our factory:

PTC Technical Characteristics		Three in series	Unit
Max work voltage	U max	25	v
Rated acting temperature	T K	120	°C
Resistance at T=25°C ± 1°C (V≤2.5)	R 25°C	≤300	Ω
Resistance at given temperature (V≤2.5)	TK-5°C	≤1650	Ω
Resistance at given temperature (V≤2.5)	TK+5°C	≥3990	Ω
Resistance at given temperature (V≤2.5)	TK+15°C	≥12	KΩ
TK acting time	TD	< 5	s

2.4 Brake and switch

2. 4. 1 Brake



The brake system of CSAG series gearless PMS elevator traction machines used is a new disc type, please check the parameters in the brake nameplate.

Due to release rings installed in the brake system of PMS elevator traction machine, user has to correctly differentiate between BK+ and BK- at the connection terminal, when connecting the power supply of the brake, preventing release rings from burning.

2. 4. 2 Microswitches

There are two micro-switches installed in the brake system. They are used to get a feed back about the brake operation. Customers can connect them according to every control system requests. There are two (2) different contacts: NC is normal closed contact, NO is normal open contact.

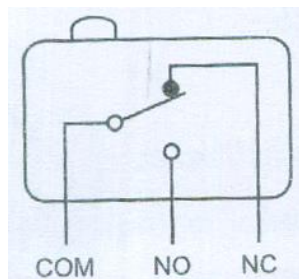

2. 5 Encoder connection



Our PMS elevator traction machines must work with most of the frequency inverters on the market, in order to control the PMS motor. The inverter must work in close-loop mode, so there must be a speed/position feed back device (we call it **encoder** in the following page).

The measuring system of the PMS elevator traction machines is matched to the associated converter.

Our factory can provide some different measuring systems on request. You can select it according to the inverter request. If you have other measuring systems please contact our technical department. We recommend the use of an appropriate cable set to connect the measuring system to the converter system. Cable sets can be supplied as accessories.

Following page shows the basic setting parameters. And you can see then more in detail in the encoder instruction manual.

2. 5. 1 Pulse Encoder

You can connect the inverter via the inverter instruction manual and the cable color/markers in the ending of cable.

HEIDENHAIN ERN 1326

Electric parameter:

- Rated voltage: $DC5V \pm 10\%$
- Rated current: $\leq 130MA$
- Resolution: 2048C/T
- Protection: IP40



2.5.2 Sin/Cos Encoder

HEIDENHAIN ERN1387

- Rated voltage: $DC5V \pm 5\%$
- Rated current: $\leq 130MA$
- Resolution: 2048C/T
- Protection: IP40



2.5.3 EnDat Encoder

HEIDENHAIN ECN1313

Electric parameter:

- Rated voltage: $DC5V \pm 5\%$
- Rated current: $\leq 160MA$
- Resolution: 2048C/T



· Protection: IP40

2.6 Earthing

Warnin

For safety reasons, it is very important that the motor be properly and carefully earthed. **Use always the earthing screw provided on the housing!** In addition, connect the protective or earthing conductor in the terminal box as specified respectively.

3. Operation and maintenance

3.1 General

The lift operator is responsible for regular checks of the brake safety components and the traction main sheave, and must include these components in his visual inspection schedules.

Dange

The regulations concerning operation, maintenance and inspection in accordance with the applicable safety regulations in lift construction such as GB/T75588-2003 (equal to EN81-1:1998) "Safety rules for the construction and installation of electric lifts"/ GBT 21739-2008 "Rules for the construction and installation of home lifts" and other relevant regulations shall be strictly observed. The operator is responsible for the requirements, which are with regard to applicable safety regulations.

3.2 Maintenance intervals

The following maintenance activities are recommending to be performed:

Check item	Judge benchmark	Cycle
Brake system	Work effective braking	Three months
Brake lining thickness		Three months
Bearing noise	No abnormal noise	Three months
Motor vibration		Three months
Load current		Three months
Sheave fix state	No loose	Six months
Sheave	No serious abrasion	Six months
Winding insulation resistance		Six months
Connection cable	No aging	Six months
Clean machine surface	No dust	As required

3.3 Maintenance regulation

Warnin

Only qualified technicians are allowed to perform any maintenance work. The technicians who perform the maintenance work must take especial care when maintenance must be done during lift or PMS machine operation.

3.4 Lubricating instructions

The main bearing of CSAG series PMS elevator traction machines should be lubricated with "Shell Albida EP2" (or same other similar lubrication) after first 5000 hours operation.

The lubricated hole is located near the rotor center (see picture below).

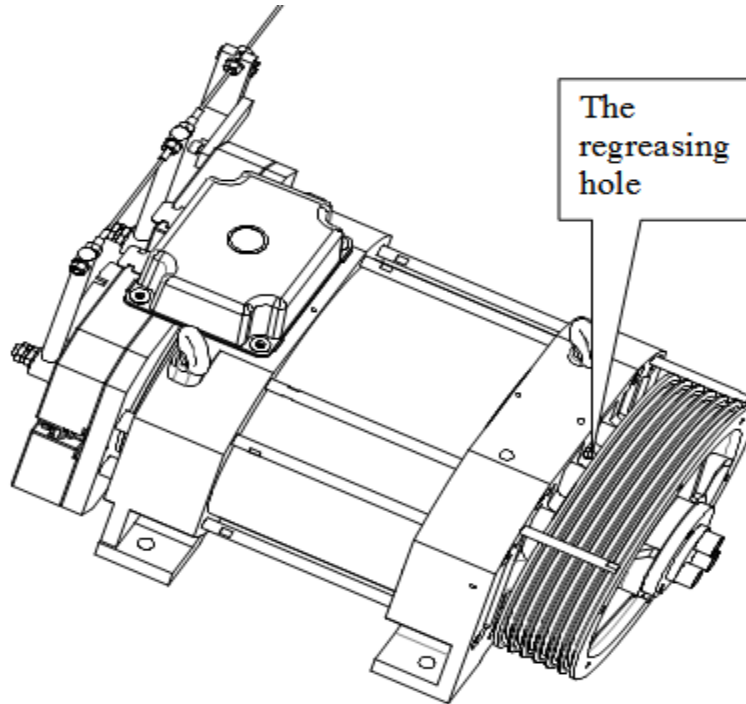

3.5 Brake operation device

CSAG PMS elevator traction machines can have on demand a manual brake handle device, which is used to allow any trapped person to escape in emergency situations. **It is forbid to use it during normal operation.** CSAG-M , CSAG-H series have only electric brake device.

Danger

Brakes are safety devices! Only qualified technicians are allowed to perform any assembly, adjusting or maintenance work!

Warnin

The brake manual handle just can be used to allow escape a person inside the lift in emergency situations and must be operated by a professional.

Brake line bending radius must be greater than 250 millimeters.

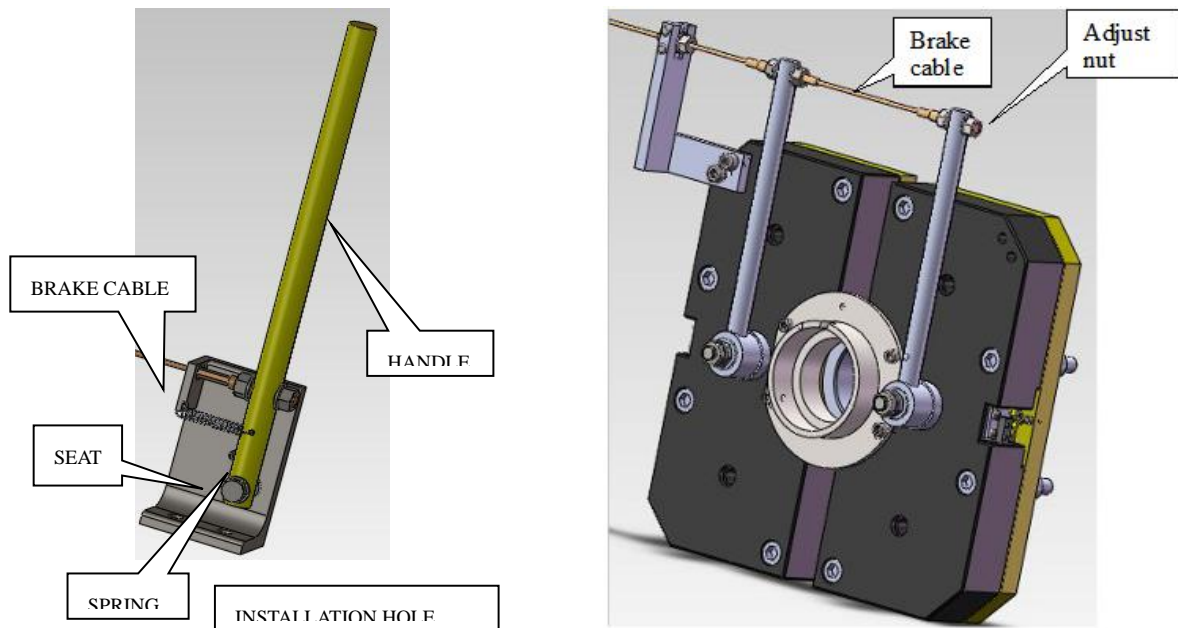

- 1.- Loosen the bolt from the lock hole,
- 2.- At the same time, pull the two handles in accordance with the direction of the arrow, release two brakes.
- 3.- The brake handles must be restored to their original condition after the operation.

3.6 Sheave replaces



Please contract the supplier to get the <Damageable Parts Replaced Manual>, if the traction sheave damaged.

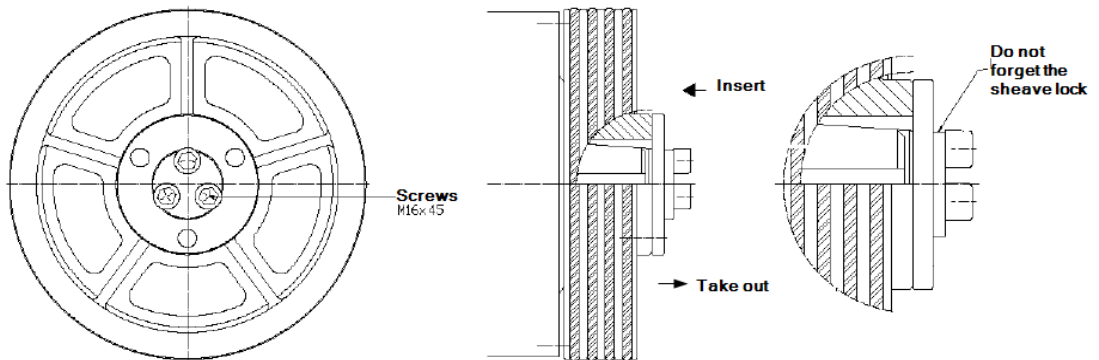

3.7 Trouble shooting



Any other repairs than those described in this operating manual are not permitted to perform. The proper maintenance of the gearless lift machines requires adequately trained specialist technicians and specific devices and parts.

Troubleshooting: Use following table to identify problems and most common solutions:

Fault	Possible cause	Corrective Action
PMS not work	a. Power cut	Check whether the connection cable is connect credibility. The interlocking device whether relief
	b. Inverter misconnection	Check the connection diagram to correct it
	c. Over load or brake not open	Brake not open completely, Inverter is over max. Limit Reduce load
	d. Inverter fault	Deal with it according to inverter instruction
	e. Wrong inverter	Change the inverter to PMSM inverter
Protect after start	a. Wrong inverter capability	Change the higher capability
	b. Inverter setting fault	Prolong the accelerate and decelerate time
	c. Over load	Prolong the accelerate and decelerate time
	d. Short-circuiting in winding	Check the winding resistance
	e. Short-circuiting to earthing	Take off the connection cable to recheck it, if still short-circuiting exchange the machine
	f. Short-circuiting in control system	Exchange the fault parts
Abnormal noise or vibration	a. Friction noise	Brake not open complete
	b. Inverter setting fault	Change the inverter PI or operating frequency value
	c. Encoder output single interfered. Encoder not fixed credibility	Connect the encoder shield Fix it again firm
	d. Bearing fault	Replace the broken bearing
Electricity in machine seat	a. Not connect the earthing	Find out the problem and correct it
	b. Winding affected with damp ,Insulation broken. Dirt in earthing connection	Desiccation the winding Repair the broken insulation parts Clean the earthing connection
	c. Connection cable insulation	Repair or exchange the connection cable
The temperature too high	Aeration, radiator not well	Remove the obstruction and the dirt

4. Brake system

4.1 General



Brakes are safety devices! Only qualified technicians are allowed to perform any assembly, adjusting or maintenance work.

The braking torque data listed in our documents are based on the following operating conditions:

- Protect the friction surfaces from oil or grease, rain, splash water, snow and ice;
- Ensure that the brake linings do not come into contact with solvent-containing media;
- Axis direction tolerance of the brake drum, including form deviations max. 0.1mm;
- Deformation of the brake drum, resulting from the application force of the brake max.0.1 mm;
- Brake disk surface with a surface roughness of not less than $Ra\ 3.2\ \mu m$;
- Brake disk steady-state temperature: max.180°C.

4.2 Brake system declaration

4.2.1 CSAG-L , CSAG-K

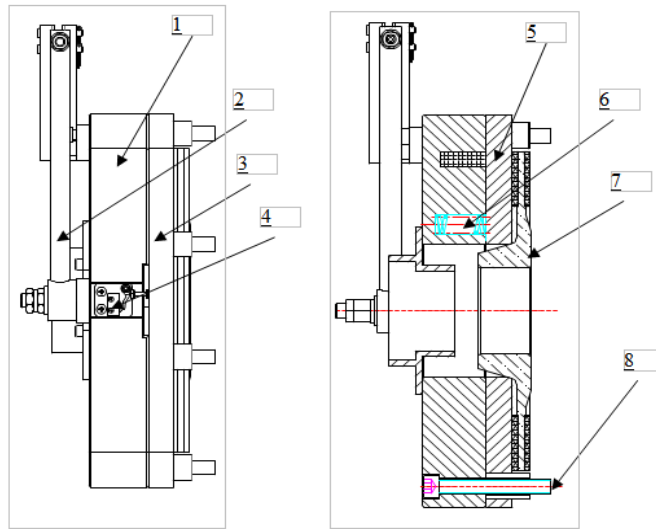

No.	Description	No.	Description
1	Static - plate	5	Coil
2	Brake lever	6	Brake spring
3	Movable-plate	7	Friction components
4	Micro-switch	8	Connected bolt

4.2.2 CSAG-N

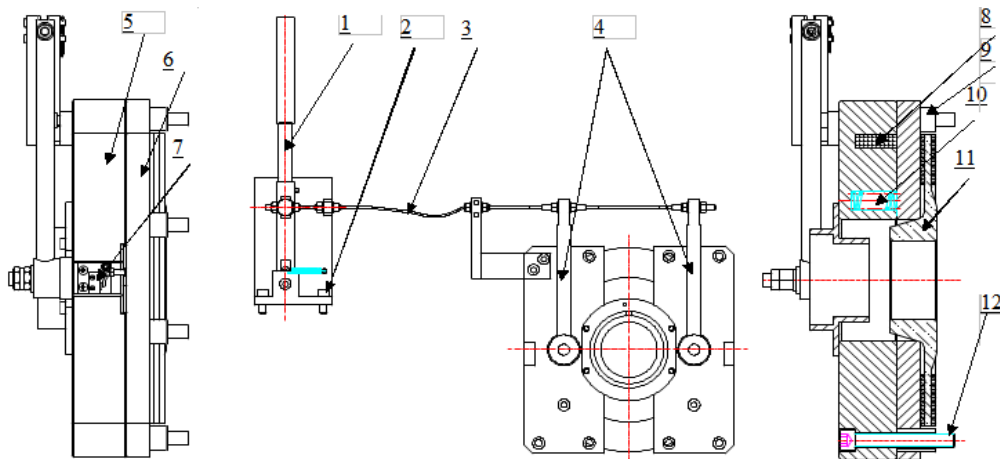

Working Stroke Gap ≤ 0.4 mm

No.	Description	No.	Description
1	Brake open Handle	7	Micro-switch
2	Installation bolt M8 (Customer-owned)	8	Coil
3	Brake release line	9	Link set
4	Brake release plate	10	Brake spring
5	Static - plate	11	Rotor (Friction disc)
6	Movable-plate	12	Connected bolt

4.3 Micro-switch adjustment

Micro-switch can monitor the state of the brake condition. Adjust the location of micro-switches. The move distance can be adjusted through the icon of the M6 adjustment bolt.

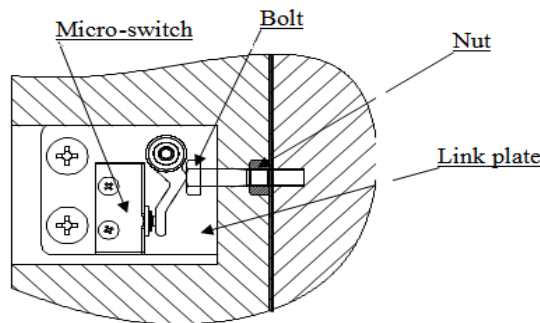

4.4 Start-up



Make sure that the functional test of the brake is only carried out when the motor is at rest, has been disconnected from the supply and is secured against inadvertent restarting.

Surface temperatures of $>80^{\circ}$ C may occur in the braking system. For this reason, no temperature-sensitive parts such as normal cables or electronic components may be routed to or fixed to the braking system. Provide appropriate protection against accidental contact, if necessary. If the motor shaft needs to be turned during adjusting work release the braking system by electric or by means of manual release, if necessary.

4.6 Trouble shooting

Fault	Possible cause	Remedy
Braking system do not work	<ul style="list-style-type: none"> a. Braking system voltage applied at excitation winding too low b. Braking torque set too large c. Brake winding broken 	<ul style="list-style-type: none"> Check brake supply voltage electrical connection Reduce brake torque setting Replace the brake winding
Braking torque can not meet request	<ul style="list-style-type: none"> a. Oil or grease on brake disk b. The distance between mobile-core and brake cap setting too big 	<ul style="list-style-type: none"> Remove the oil Change the brake lining
Brake system no feed back	<ul style="list-style-type: none"> a. Microswitch broken b. The position of microswitch is install not correct 	<ul style="list-style-type: none"> Replace the broken winding Readjust the microswitch install position

5. Synchronization with inverter

5.1 General



The synchronization with the inverter work must be done by qualified electric technician. During connexion, unexpected movement may occur, always fix the PMS elevator traction machine in a fixed frame before start any attempt

5.2 Checking before usage



Before start work make sure that the traction machine, encoder and brake are connected correctly. Do not forget the insulation and earthing!

Check that power specifications of the site and earthing cable are correct. Using a temporary power supply is not recommended, if in exceptional cases needs to be used, it must have the safety isolation included from the power supply.

5.3 Motor parameter setting

Inverter parameters are divided in two parts: PMS parameters and system position (PG) learning. You need to enter some mandatory parameters into the inverter on this process.

There are two different methods to set the parameters into the inverter :

- a. Set the factory value nameplate or in operation manual to the inverter direct.
- b. Setting just basic parameters and then use the inverter motor learning function to lean the other parameters.

Because there are so many different inverter models and inverter manufacturers in the market, and them have different parameter name, expressive manner or units to each parameter, you can follow the detail of the motor learning method in the inverter instruction manual.

5.4 Inverter self- learning condition and method

Inverter self-learning is a very important part of the process when installing the PMS, and is critical to have the PMS traction machine running steady and safe in the future.

Following condition must be insured before to start the self-learning operation mode :

- a. Verify there is no load in sheave (before hang up the rope);
- b. Check the the brake is connected and the sheave can running free;
- c. Encored mechanical install and signals connection correct;
- d. To be familiar with the performance and settings of the inverter you use.

In order to perform the synchronization process successfully, please do it according to following steps:

- a. Plug in correctly the inverter, set the parameter of PMS elevator traction machine and encoder. Then turning the sheave in both directions to check whether the inverter speed feed back is correct. If the inverter court failure, please check the connection and the setting.
- b. Start the self-learning function then read out the parameter, and do it about 10~15 times the tolerance must with 10%.



The motor speed abnormal or vibration too big may happen during this process. This may be cause by the wrong connection of motor phase. You can do it again after replace the discretionary two phases. There may have some difference in different inverter self-learning process, you can do it according to the inverter instruction manual requests.

- c. Set the motor to run at both directions at a low speed to check whether operation is steady and it can start and stop under the inverter commands.
- d. Set the inverter parameters to final state and let it running in the rated speed to check the no-load current is normal.

5.5 Inverter connexion

Use the CONNEXION CABLE provided with our PMS or contact our technical department to buy specific spare cables. However, in case you need to connect the inverter using the color cable, here we enclose instructions for the mos common inverter models

5.1.- FUJI Inverter

1	PO	3	CM	CM	PA +	PA -	PB +	PB -	CK +	CK -	DT +	DT -	14	15	16
	Up		Pantalla interna	0V	A +	A -	B +	B -	CLOCK	CLOCK	DATA	DATA			
	Negro		Tubo retráctil Negro con terminal rojo	Lila	Blanco	Marrón	Verde	Amarillo	Azul	Rojo	Gris	Rosa			

Internal Shield: Black retractile tube (RED terminal). Connect with CM

External Shield: Black retractile tube (BLUE terminal). Connect with FE (Encoder Earth)

5.2.- YASKAWA Inverter

IP	IG	CK	CK	A+	A -			FE
Up	0V	CLOCK	CLOCK	A +	A -			
Negro	Lila + malla interna	Azul	Rojo	Blanco	Marrón			Malla externa

IP	IG	DT	DT	B+	B-
Up	0V	DATA	DATA	B +	B -
(1)	(1)	Gris	Rosa	Verde	Amarillo

Internal Shield: Black retractile tube (RED terminal). Connect with PURPLE at 0V

External Shield: Black retractile tube (BLUE terminal). Connect with FE (Encoder Earth)

(1) It is the same to choose between IP and IG (left or right)

5.3 SUMPO Inverter

5.3.1.- CONNECTION

5.3.2.- MOTOR PARAMETERS INPUT

5.3.3.- SPECIAL PARAMETERS SELECTION

5.3.4.- SELF-STUDY OF MOTOR

5.3.5.- MOTOR RUNNING

5.3.1.- CONNECTION

Connect the encoder cable to the terminal block of the motor.



of



Be careful that the mark on the encoder cable must be coincident with the mark on the terminal block .

1b	6a	4b	3a	2a	5b	4a	3b	6b	1a	2b	5a
Up	Sensor Up	0V	Sensor 0V	A+	A-	B+	B-	DATA	$\overline{\text{DATA}}$	CLOCK	$\overline{\text{CLOCK}}$

5.3.2.- MOTOR PARAMETERS INPUT

Press the upward button or downward button of the control panel, until the “A1.01.” appears on the screen, press “ENTER” to enter E - motor parameter input function menu, select “E2.01.”, press “ENTER”, input the motor parameters successively:

E2.01. rated power of the motor

E2.02. poles of the motor

E2.03. rated current of the motor

E2.04. rated voltage of the motor

E2.05. frequency of the motor

E2.06. rated rpm of the motor

5.3.3.- SPECIAL PARAMETERS SELECTION

A1. The hardware parameter input: Press the upward button or downward button, until “A1.01.” appears on the screen, press “ENTER”, input **A1.06 = 7**

A2. The control parameter input: Press the upward button or downward button, until “A1.01.” appears on the screen, press the right arrow button, enter the “A2” function menu, select “A2.01.”, press “ENTER”, input **A2.01. = 5**



B1. Run mode parameters input: Press the upward button or downward button, until “A1.01.” appears on the screen, press “ENTER”, go to “B1” function menu , select “B1.01”, press “ENTER”, then input the parameters successively :

B1.01.=0

B1.02.=0

B1.04.=0

E5. ASR characteristics parameter input: Press the upward button or downward button until “A1.01.” appears on the screen, press “ENTER”, go to “E” function menu, select “E5”, press “ENTER”, then input the parameters successively :

E5.01=5

E5.02=5

E5.03=2

H5. Encoder input/output parameters: Press the upward button or downward button, until “A1.01.” appears on the screen, press “ENTER”, go to “H5” function menu, select “H5.01”, press “ENTER”, then input the parameters:

H5.01.=2048

5.3.4.- SELF-STUDY OF MOTOR

After the configuration of the all the above parameters, now we could go to “SELF–STUDY” Step:

OP3 Motor Self–study parameter: Press the upward button or downward button, until “OP1” showed on the screen, press the right arrow button, select “OP3” , press “ENTER” , then input the parameters and finish every step successively:

1. Input OP3=0, press “RUN”, Self-study (no need to open the disk brake)
2. Input OP3=1, press “RUN”, Self-study (no need to open the disk brake)

5.3.5.- MOTOR RUNNING

After the SELF–STUDY Step, you could start to run the motor with the inverter.

Press “ENTER” , return to the main menu, at the main menu, input the rated frequency “**XX Hz**” of the motor , press “**RUN**” , the motor starts to work .

Anexe I. Encoder installation

I.1 General

Caution

Installation, checking and replace of the encoder must be down by qualified maintainer at power cut state.

If the customer ordered the encoder when order the PSM elevator traction machine, the encoder will be installed and tested before it leaving factory.

If the customers buy the encoder yourself, you can install it according to following step:

I.2 Installation regulation

Caution

Encoder is a very exact equipment part so it must be take care during installation.

I.3 Installation

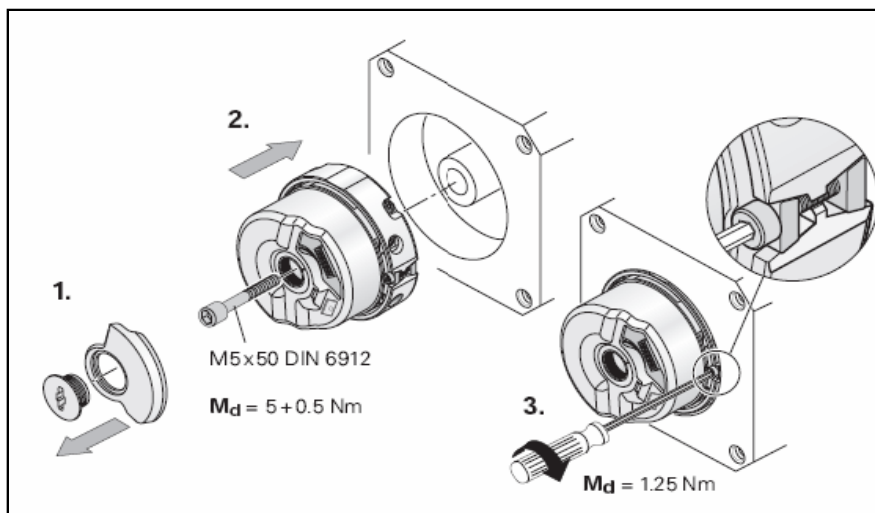

- a. Open the rear cover;
- b. Take off the burr in connection cone hole;
- c. Open the encoder cover then pull the cone shaft into the cone hole. Use the fix bolt accessory of encoder though the encoder to fix the encoder in the shaft. Finally connect the signal cable and cover the rear cover.